

ACCURATE GAS CONTROL SYSTEMS, INC.

AGT354D

Chiller/Heater Recirculator

Installation and Operation Manual

Table of Contents

1.0 General Information	2
2.0 Technical Specifications	3
2.1 Mechanical	
2.2 Electrical	
3.0 Installation	4
3.1 Mechanical Installation	
3.2 Electrical Connections	
3.3 Fluid Connections	
4.0 Explanation of Controls	8
4.1 Front Panel Controls	
4.2 Controller	
4.2.1 System Architecture	
4.2.2 Modes of Operation	
4.2.3 Menu Operation	
5.0 Operation	13
6.0 Maintenance	14
6.1 Maintenance Schedule	
7.0 Troubleshooting	16
8.0 Parts List	20
9.0 Parts Replacement	21
Warranty Policy	22
Layout Drawings	23
Electrical Schematic	



1.0 GENERAL INFORMATION

The AGT354D Recirculator is a high performance heavy-duty industrial recirculator designed to circulate fluid through a remote system in a closed loop configuration. Temperature control of the remote system is accomplished by a heat exchange process between the system and the recirculator via the circulating fluid. A powerful heater is controlled by a microprocessor based proportional, integral and derivative (PID) controller. Heat is added to the system to modulate the net cooling power of the non-CFC refrigeration system.

A reliable capillary type non-CFC, DuPont's R134a SUVA™, refrigeration system provides the cooling power for the AGT354D Recirculator. This type of refrigeration system is basic in the design and does not employ expansion valves or solenoid switches as in more complicated systems.

Fluid temperature is measured with a platinum resistive thermal device (RTD) sensor. Both the process and set point temperature are clearly displayed on the controller. Temperature control to $\pm 0.1^{\circ}\text{C}$ is possible based on the accurate RTD input signal, the controller's fast time-based (200ms) output and a large reservoir.

The AGT354D has a 12 Liter (3.2Gallon) reservoir providing a large thermal mass for temperature stability, and thereby, maintaining accurate temperature control of the fluid. The fluid is drained out of the bath into a positive displacement pump. A high torque motor is coupled to a pump for delivering a constant flow rate regardless of the backpressure up to 160 PSI. A pressure transducer is used to measure the backpressure of the entire system. The pump's internal bypass will activate for pressures greater than 160 psi.

The AGT354D has the following features included as standard equipment:

- Adjustable high and low temperature process and limit alarms. Settings are accessible on the controller and red LED indicates an alarm condition.
- A standard latching $50^{\circ}\text{C} \pm 4^{\circ}\text{C}$ thermal safety switch with a red "Interlock Fault" indicates this alarm condition.
- A "Low Level" alarm to indicate a low fluid level condition in the reservoir.
- A 2.8-gallon per minute positive displacement circulation pump
- Audible alarm horn
- 4-20mA analog output for remote temperature monitoring
- Serial communications for remote system interface and remote temperature monitoring.
- One Form C alarm relay for customer interconnect.
- Remote user interface architecture.



2.0 TECHNICAL SPECIFICATIONS

2.1 Mechanical

Temperature Range:	
	<i>Standard</i> 0°C to 50°C (32°F to 122°F)
Temperature Control System:	Digital Controller, PID
Display Resolution:	±0.1°C (±0.2°F)
Temperature Sensor:	100Ω Platinum 3-wire RTD
Cooling Capacity [20.0°C (68°F)ambient]:	250 Watts (938 BTU/hour) @ 4.0°C (39.2°F)
	675 Watts (2300 BTU/hour) @ 20.0°C (68°F)
Maximum Flow Rate:	10.6 LPM (2.8 GPM)
Refrigerant:	DuPont R-134a SUVA™, non-CFC 5.5oz for 110V 1/4hp units 6.5oz for 220V 1/3hp units
Reservoir Capacity:	12 Liters (3.2 Gallons)
Dimensions, H x W x D:	73 x 42 x 42 cm (28.5" x 16.5" x 16.5")
Weight:	58 kg (127 lbs.)

2.2 Electrical

Electrical Specifications		
Model	AGT354D-1	AGT354D-2
Voltage	115 ± 10 Volts	230 ± 20 Volts
Frequency	50/60 Hz	50/60 Hz
Phase	Single	Single
Maximum Power Consumption	2875 Watts	3370 Watts
Circuit Requirements	115V, 30A, 1Ph, 50/60Hz	230V, 15A, 1Ph, 50/60Hz
Connection	NEMA L5-30P plug	Not supplied



3.0 INSTALLATION

3.1 Mechanical Installation

Find a solid and level surface able to support the weight (127 lbs., 58 Kg) of the AGT354D recirculator. Four casters are mounted to the AGT354D to conveniently move the unit to the desired location. Use floor mounted bracketing to brace the AGT354D recirculator if the location is subject to movement.

The most stable and uniform performance will be obtained by locating the AGT354D recirculator in an area remote from drafts, ventilation outlets, radiators, and other rapidly changing ambient conditions. Allow at least a 12" space around the AGT354D to assure proper ventilation.

Do not place AGT354D Recirculators next to each other unless panels are placed between them to divert the hot exhaust from the left unit entering the intake of the right side unit. The condenser coil is located on the left side of the unit where air enters and flows across the coil to remove heat. The condenser coil should never be blocked and must be free of dirt and dust for proper and efficient cooling performance.

Do not place AGT354D Recirculator against an object that will block airflow across the condenser coil. Ventilation openings on the left and right side of the unit must be open to allow air to pass. The condenser coil must be free of dirt and dust for proper and efficient cooling performance.

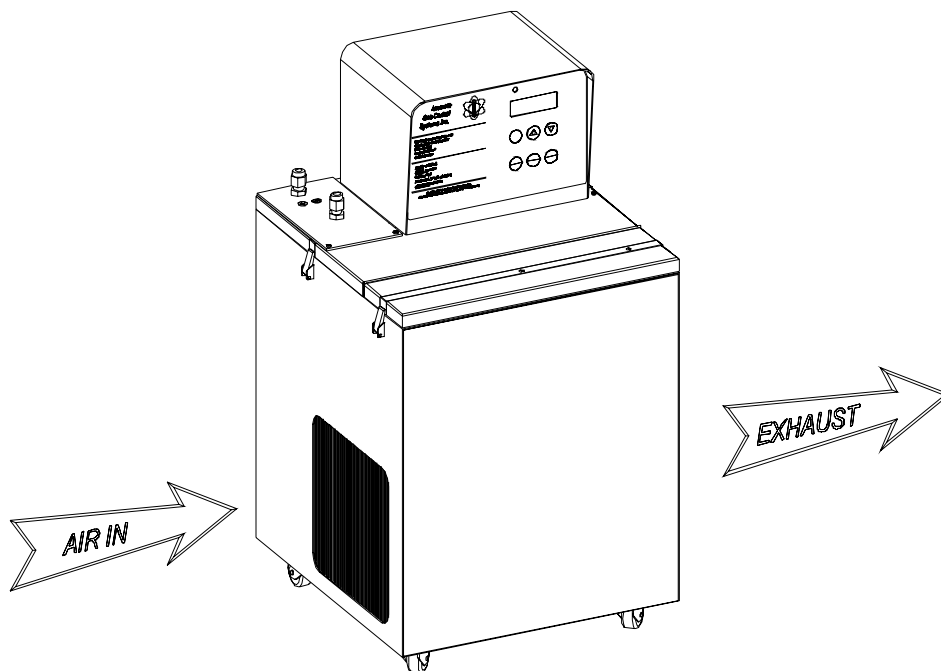

3.2 Electrical Connections

3.2.1 Power Connections

The customer is responsible for supplying the correct electrical circuit and receptacle for operating the AGT354D Recirculator. Have a qualified electrician check the circuit for proper size, grounding, and electrical connection.

Model AGT354D-1 operates on 115 Volt, single phase, 60Hz and comes equipped with a 3- pin, 30A, 120V, NEMA type L5-30P plug.

Model AGT354D-2 operates on 230 Volt, single phase, 50 HZ. The customer must supply the electrical plug due to the various electrical receptacle configurations in different countries. The AGT354D-2 should be plugged into an electrical circuit that is rated for 230V, 20A, 1Ph and 50Hz.

Warning: Do not, under any circumstances, remove the ground pin from the power cord or use a two-pin adapter. Make sure that AGT354D is properly grounded.



3.2.2 Alarm Interconnect

A 4-pin circular plastic connector (CPC), found on the back of the upper control housing, is used to connect with the AGT354D alarm relay. The alarm relay is a Form C relay, with one (1) normally closed contact and one (1) normally open contact. The relay common is Pin 1 (at the 12 o'clock position). The normally open is Pin 2 (at the 3 o'clock position). The normally closed is Pin 4 (at the 6 o'clock position). Refer to the electrical schematic in the appendix for further information. Cables are available from the factory.

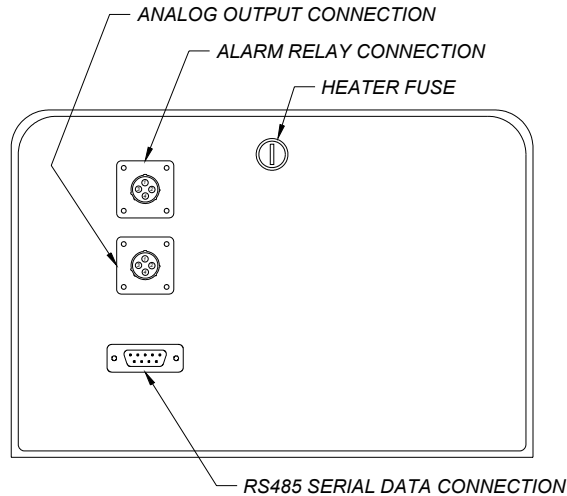

Figure 1.
Back Side of Upper Control Housing

3.2.3 Analog Output Connections

A 4-pin CPC, found below the alarm connector, is used to connect with the AGT354D analog output. The analog output is a 4 to 20mA signal, which is proportional to the process temperature. The signal output positive (+) is Pin 1 (at the 12 o'clock position). The signal negative (-) is Pin 2 (at the 3 o'clock position). Refer to the electrical schematic in the appendix for further information. Cables are available from the factory.

3.2.1 Serial Data Connections

A 9-Pin D-Port connector is used to interface serial data with the control module. Form RS485 digital signals are made on Pins 1 and 6. The Common is connected to Pin 5. See Section 4.2.1 System Architecture for further information on serial interface. Application Program Interface (API) instructions are covered in a separate document – UCM API Manual Document Number 30011.



3.3 Fluid Connections

The AGT354D has 3/8-inch female compression fittings for discharge and return fluid connections located on the upper left side. The discharge port is located on the backside of the unit.

All required fittings and tubing are supplied if the AGT354D is supplied with an AG106 Single Connection Kit or AG108 Dual Connection Kit as part of an AG-System. Close proximity of the AGT354D to the system, and insulating the remote plumbing lines improves temperature control. The AGT354D should be located close to the system to be controlled to minimize the length of tubing required, and thereby, reducing the backpressure. The user is responsible for providing appropriate extension tubing able to handle the application temperature and pressures for the systems. Suitable tubing sizes are 3/8" and 1/2".

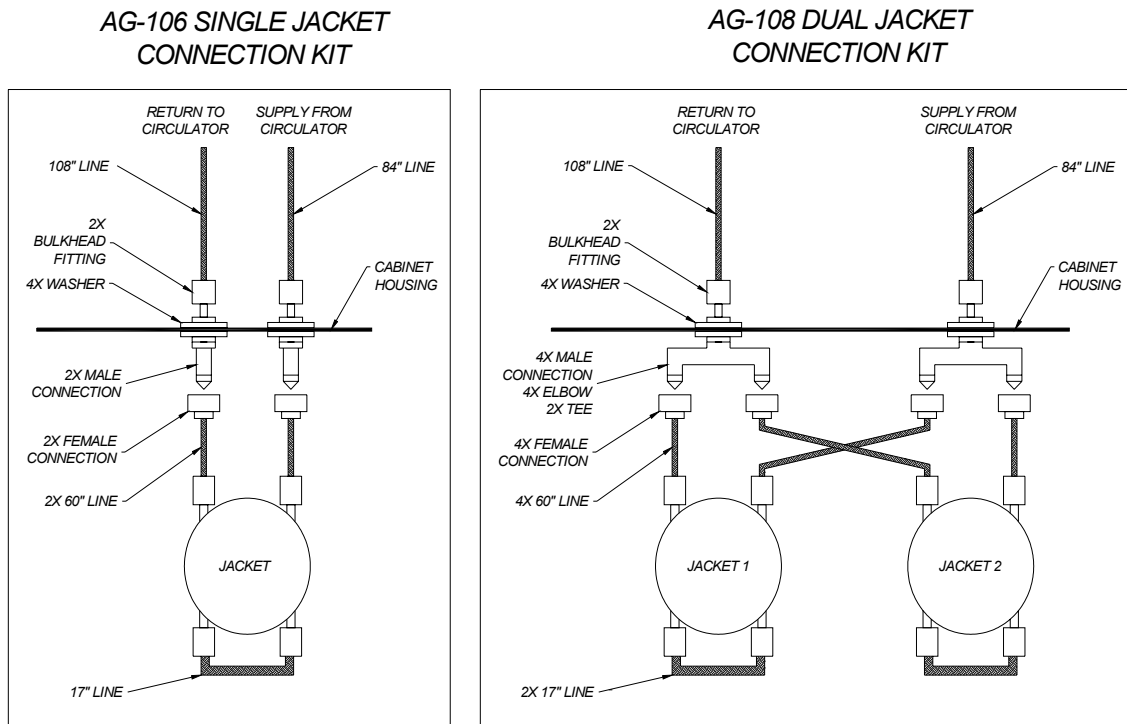

Figure 2.
Fluid Connections for
AG Cylinder Jackets



4.0 EXPLANATION OF CONTROLS

4.1 Front Panel Controls

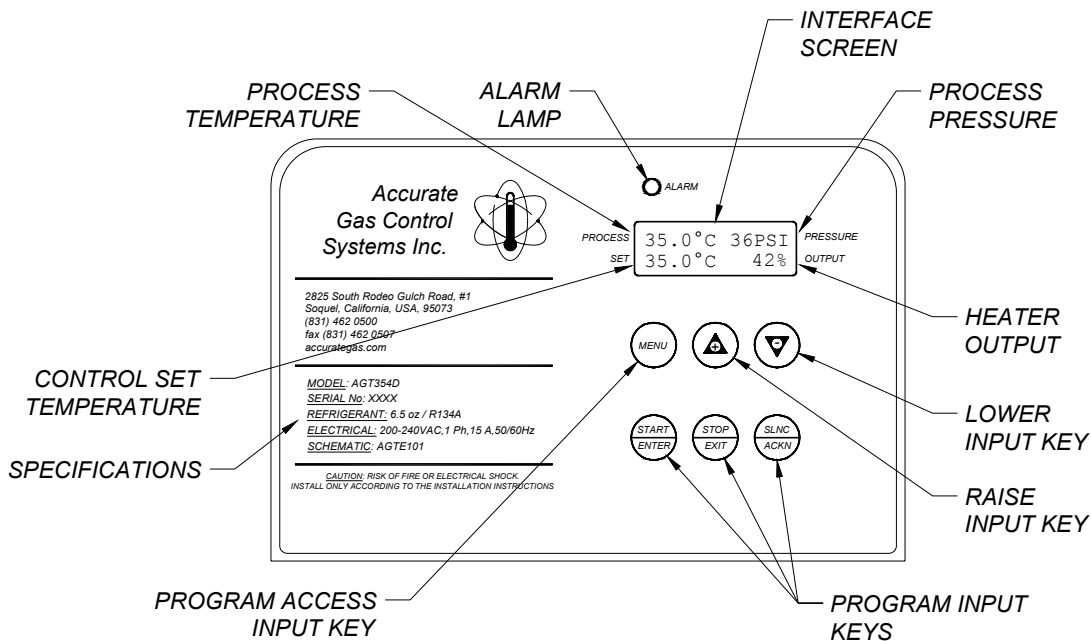

Figure 3.
Front Panel Controls

Interface Screen

A 2x16 character LCD display is used as the primary interface. In Run Mode the display shows process and control values. In program mode the display shows messages and settings. In Ready Mode the display will show alarms or ready status.

Alarm Lamp

A multi-colored LED will indicate mode and alarm status. A green lamp indicates Run Mode Enabled. A red lamp indicates a process alert or an alarm condition. An audible alarm will accompany a process alert or alarm. The audible alarm will continue until the operator has acknowledged the condition.

Process Temperature

In Run Mode the interface screen will display the process temperature in the upper left corner. Temperature units for this display will also be shown. Tenths of one degree Centigrade will be shown or half degrees in Fahrenheit.

Control Set Temperature

In Run Mode the interface screen will display the control setpoint in the lower left corner. Temperature units for this display will also be shown.

Process Pressure

In Run Mode the interface screen will display the process supply pressure. Pressure units for this display will also be shown.



Heater Output

In Run Mode the proportional, integral and derivative controlled heater output will be shown on the interface screen in percent. This output is 1500W at 100% and full nominal input voltage.

Program Access Key

The Menu key allows instant access to the controller settings and configuration. In menu mode the Menu Key is used to save parameters that have been changed.

Program Input Keys

The three keys on the lower section of the control panel are used for different operations in each mode. In Run Mode the keys are used to Start and Stop the unit and to Silence alarms. In program mode the keys are used to Enter parameters and Exit program levels. In Alarm Mode the left lower key is used to acknowledge machine conditions and to clear alarms.

Raise and Lower Keys

The up and down marked keys are used only in program mode. Use these keys to increase and decrease values or scroll through menu levels.

Power Circuit Breaker Switch:

Located on the upper rear corner of the right panel a circuit breaker switches all the electrical power to the unit. In the event of an over current, the breaker will trip and disconnect the electrical power to the unit. The unit needs to be restarted manually in case the circuit breaker is tripped.

Fuse:

The heating circuit of the AGT354D is protected with a fuse. The fuse holder is located on the back of the upper housing. A 15A, 250V fuse is used in the AGT354D-1 (110V) unit. An 8A, 250V fuse is used in the AGT354D-2 (220V) unit.



4.2 Controller

4.2.1 System Architecture

The AGT354D uses a control and interface system to detect process variables, control processes, manipulate logical inputs and outputs, and to interface with the operator. The interface module allows the operator to send commands and read process data from the control module. The control module is able to function independently without the use of an interface. Several interface variations are available. Figure 3 shows various interface systems.

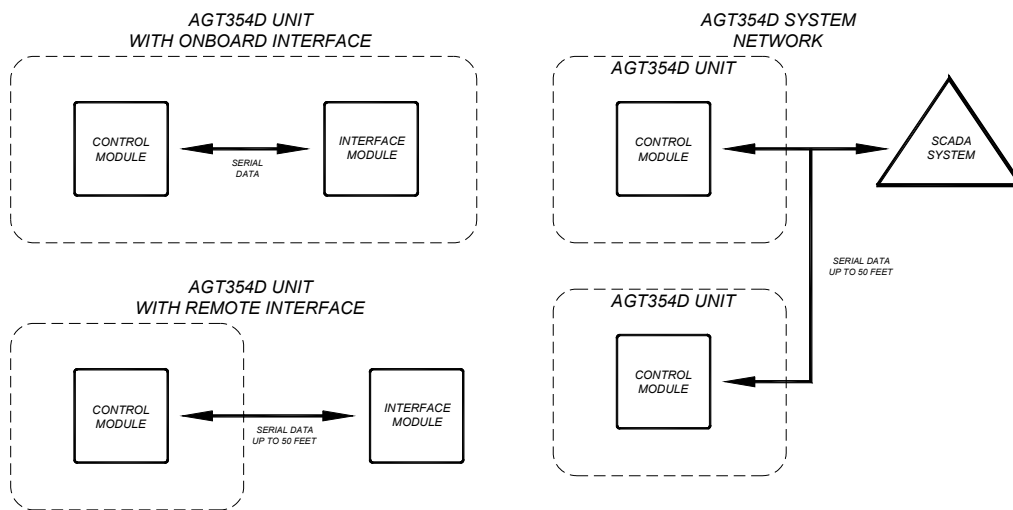

Figure 4.
Interface Architectures

The standard AGT354D is shipped from the factory with a fully integrated onboard interface. This integrated interface allows the user to operate the unit from the front control panel. This manual covers the operation of the onboard interface.

The standard interface can be remotely mounted from the unit. The interface can be separated by up to 50 feet from the unit. This configuration allows for remote interface and integration with gas system controllers.

The control module can also communicate with other programmable interface systems. The control module uses a standardized serial data protocol and variable index. Several units can be connected to one Supervisory Control and Data Acquisition System (SCADA). Application Program Interface (API) instructions are covered in a separate document – UCM API Manual Document Number 30011.



4.2.2 Modes of Operation

The control interface uses 5 modes of operation. When power is applied to the unit the controller begins in a Self-Diagnostic Mode. In diagnostic mode the controller checks for operation of critical components and system inputs and outputs. If no errors are detected in diagnostic mode the controller will display a hardware and software revision and proceed to Ready Mode. If the controller detects a system fault the controller will proceed to Alarm Mode and display these errors. From Ready Mode the operator can start the unit and the controller will proceed to Run Mode. In Run Mode process values are displayed on the interface screen and the unit will control the process. The operator can stop the unit and the controller will return to Ready Mode. An alarm condition or system fault will cause the controller to stop and proceed to Alarm Mode. Alarms and fault will be displayed on the screen. These conditions must be cleared and acknowledged before the controller will return to Ready Mode. Menu Mode can be accessed from Ready Mode or Run Mode by depressing the Menu Key. Once in Menu Mode the controller will carry out functions and settings until changed. To leave Menu Mode depress the Exit Key and the controller will return to the current mode.

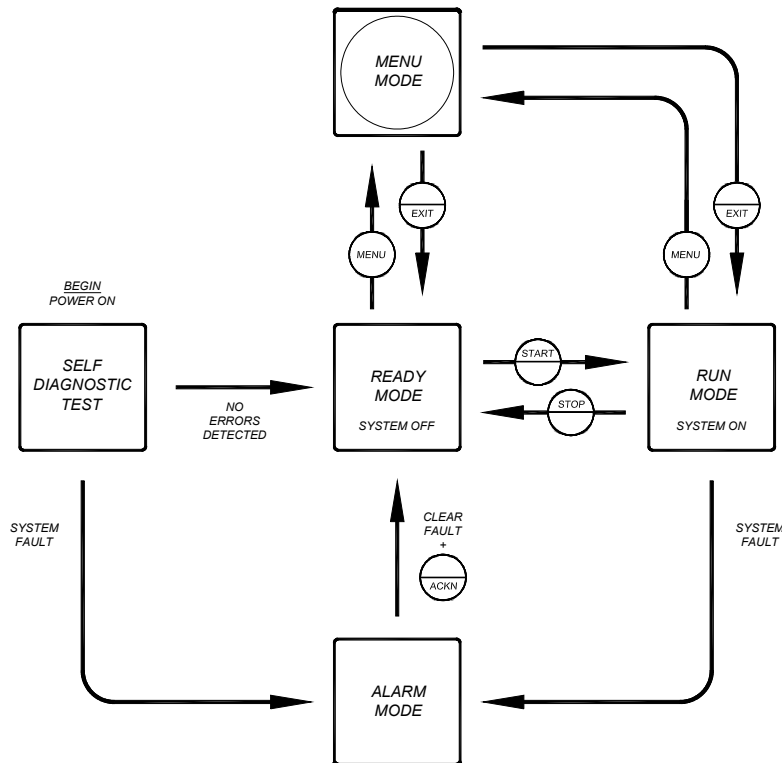

Figure 5.
Modes of Operation



4.2.3 Menu Operation

The menus are organized into two levels. The primary level allows the operator to make basic setting adjustments. The second level allows the operator to change the configuration of the system and is password protected.

Menu Mode can be accessed from Ready Mode and Run Mode by depressing the Menu Key. The ENTER, EXIT, MENU, Raise and Lower Keys are used to scroll, select and change variables in Menu Mode. Use the Raise and Lower Keys to scroll through the menus. To select a variable to change depress the ENTER Key. Use the Raise and Lower Keys to increase or decrease the value. Depress the MENU Key to save the adjustment that you have made. To leave Menu Mode depress the EXIT Key.

The following table shows all system variables in the primary menu level.

Code	Factory Setting	Description	Range
SETPOINT	20.0 °C	Process set point	4.0 to 50.0 °C
AUTOTUNE	OFF	Auto tuning routine	Start or Stop
HI DEV	5.0 °C	High deviation warning	0.0 to 50.0 °C
LOW DEV	5.0 °C	Low deviation warning	0.0 to 50.0 °C
PBAND	1.6	Proportional control constant	0.1 to 999.9
IBAND	130	Integral control constant	0 to 9999
DBAND	5	Derivative control constant	0 to 9999
TEMP UNITS	°C	Temperature control units	°C or °F
PRESS UNITS	PSI	Pressure indication units	PSI or kPa

To access the higher level menu enter the Menu Mode and use the Raise and Lower Keys to scroll to HIGH LEVEL MENUS screen. Depress the ENTER Key and then use the Raise Key to adjust the code to 10. Depress the MENU Key to continue to the higher level menus.

The following tables show all system variables in the higher menu level.

Code	Factory Setting	Description	Range
SP MAX	50.0 °C	Maximum program set point	-20.0 to 70.0 °C
SP MIN	4.0 °C	Minimum program set point	-20.0 to 70.0 °C
OFFSET	0.0 °C	Sensor offset	-20.0 to 20.0 °C
HIGH PROC	50.0 °C	High process alarm temperature	-20.0 to 70.0 °C
LOW PROC	0.0 °C	Low process alarm temperature	-20.0 to 70.0 °C
HI PRESS	160 PSI	High pressure alarm	0 to 200 PSI
LOW PRESS	5 PSI	Low pressure alarm	0 to 200 PSI
SET LINE	60 Hz	Electrical service frequency	50 or 60 Hz
ORG FACTORY SET	OFF	Reset control parameters to factory default	MENU or Exit



5.0 OPERATION

- 5.1 Plug the AGT354D into an appropriate electrical receptacle. Check the serial plate for power requirements on your unit or refer to Section 3.1 Electrical Connections. A circuit rated for 30 Amp, 120 Volt, 60 Hz will be required for the AGT354D-1. A circuit rated for 20 Amp, 230 Volt, 50 Hz will be required for the AGT354D-2.
- 5.2 Unlatch and lift the front lid and pour Thermex-E™ into the reservoir. Fill the reservoir to within 1-½ inches from the upper rim of the reservoir.
- 5.3 Switch the circuit breaker, located on the right upper rear side, to the ON position. Allow the controller to power up and go to Ready Mode.
- 5.4 Depress the Start switch. The unit will come on and begin to pump Thermex-E™ and control the process.
- 5.5 Check the level in the reservoir. Additional fluid may be needed as the jackets and lines fill. If the unit displays a “Level Alarm” add more Thermex-E™. Fill the reservoir to within 1 ½-inches from the upper rim of the reservoir.
- 5.6 Check the supply pressure on the display. The pressure should be lower than 100 PSI and never greater than 120 PSI. An operating pressure of 5 PSI to 60 PSI will work well for most applications. Lower operating pressure will prolong the life of the pump and motor.
- 5.7 Adjust the set point. Depress the MENU Key to enter Menu Mode. The first screen that will appear is the Change Setpoint Menu. Depress ENTER to change the current set point. Use the Raise and Lower Keys to adjust the value to the desired process temperature. Depress the MENU Key to save the adjustment that you have made. Depress the EXIT Key to return to Run Mode.

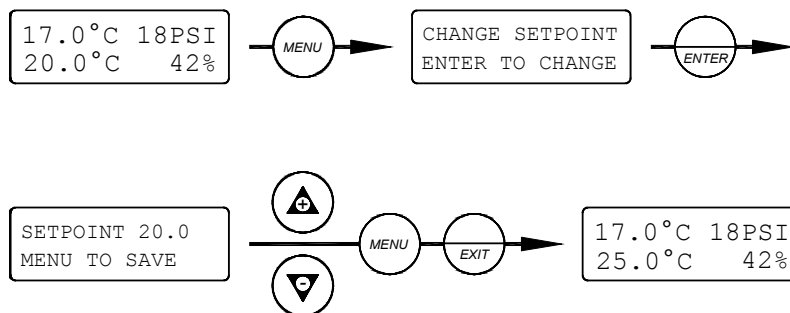

6.0 MAINTANANCE

Regular maintenance of the AGT354D will provide years of trouble free performance. Below is a list of major components that should be checked and maintained followed by a detailed maintenance schedule.

Pump Motor

A carbonator motor drives the recirculation pump. With constant usage the 110V motor will need lubrication every 6 months. Remove the back lower panel to the AGT354D to gain access to the pump motor. Two oil ports are located on the upper side of the 110V motor. The ports are capped with small yellow plugs. Remove the plugs and drip 15 drops of SAE 20 motor oil into each port. Replace the caps when complete.

The 220V motor has sealed bearings and does not require lubrication.

Condenser Fins

The refrigeration system of the AGT354D is an air-cooled, non-CFC, condensing unit. Air is drawn into the unit across the condenser coils. The condenser coil is located on the left side of the unit. The airflow through the coil removes heat from the system. For efficient and proper cooling it is imperative to keep the coils free of obstruction such as dirt and lint. Use a vacuum cleaner, air hose or a brush to remove the debris collected on the fins. Be careful not to damage the condenser fins.

Reservoir

Changing the fluid occasionally will prevent mildew growth and remove particulate that can damage the pump. A change of fluid once a year is recommended. More frequent changes may be required depending on the application. The frequency of changing the fluid depends of the degree of growth and cleanliness. Warmer operation temperatures promote algae and mildew buildup, therefore, a more frequent fluid change is recommended.

Use the following procedure to drain the reservoir.

- *Set the operating temperature to 0° C*
- *Disconnect the return line on the manifold and place a bucket underneath the tubing.*
- *Press the green Start switch and allow the pump to empty the reservoir. When the reservoir is empty press the red Stop switch to stop the pump. **Do not let the pump run dry for more than 30 seconds.***



6.1 Maintenance Schedules

Following is a schedule of preventative maintenance inspections and procedures to be performed for the maximum performance and useful service life from your recirculator. In case of malfunctions, refer to Section 7 Troubleshooting.

Every Month

- Lift the reservoir lid and check the Thermex-E level. The level should be within 1 ½-inches of the rim. Add Thermex-E as required. If the Thermex-E level is low, not within 3-inches of the rim, check the unit for leaks.
- While the unit is running, lift the reservoir lid and make sure that Thermex-E is circulating.
- Clean the condenser coil on the left side of the unit.
- Check for airflow through the unit. A fan mounted behind the condenser draws air through the unit.
- Check the controller display for set point and operating temperature. The unit should display an operating temperature within $\pm 0.1^{\circ}$ C of the set point on the display.
- Check for alarm conditions on the controller.

Every 6 Months

- Perform all monthly maintenance inspections and service.
- Lubricate pump motor with 15 drops of SAE 20 nondetergent oil. Put 15 drops in each of the oiling portholes, which are located on the topside of the motor. The oiling ports are plugged with yellow removable caps. 220V motors have sealed bearing and do not have oil service ports. Disregard this service on 220V units.
- Lift the reservoir lid and inspect the fluid cleanliness. If there is dirt or buildup in the reservoir it should be cleaned and the fluid should be replaced. Always use Thermex-E™ fluid in the AGT354D.

Every 12 Months

- Perform all monthly and 6 month inspections and service.
- Inspect the motor and pump shaft coupling. Remove the back panel of the AGT354D. Loosen the V-Band clamp holding the pump to the motor. Pull the pump away from the motor and check for wear on both shafts. Look for the presence of a dark powder. If the shafts look intact and show little wear reinstall the pump. Make certain the pump flange is flush with the motor flange and that the shafts are lined up. Tighten the V-Band clamp, replace the back panel, and run the unit checking for circulation.



<i>Symptom</i>	<i>Possible Cause</i>	<i>Remedy</i>
<p>No heat (Run away cooling) - continued</p>	Failed Heater	<p>Check heater (HR1). Disconnect and check resistance between poles. Resistance values should be $9.6\Omega \pm 10\%$ for 115V units or $32.3\Omega \pm 10\%$ for 220V units. Resistance to ground should be greater than 100,000Ω. Replace if not in specification.</p>
	Failed Relay	<p>Check relay (SSR). Check for 24VAC on the poles 3 and 4. If present, check for voltage on poles 1 and 2. Replace if no output on pole 2.</p>
	Failed Controller	<p>Power system down and restart. Check that set point is higher than process temperature. If true, then output indicator shows percent output. If output is indicated check for output voltage to SSR. If not functioning correctly replace controller module.</p>
<p>Continuous heat (Run away heating)</p>	Failed Temperature Sensor	<p>Check sensor (RTD) wire connections at J10 on the controller module.</p> <p>Disconnect and check resistance between the red leads and white lead. Values should correspond to specifications in Table Platinum RTD Sensor. If out of specification replace sensor.</p>
	Failed Relay	<p>Check relay (SSR). Check for 24VDC on the poles 3 and 4. If not present, check for voltage on poles 1 and 2. Replace if output on pole 2.</p>
	Failed Controller	<p>Power system down and restart. Check that set point is lower than process temperature. If true, then display will indicate no output. If no output then check for output LED on SSR. If there is output replace controller.</p>



<i>Symptom</i>	<i>Possible Cause</i>	<i>Remedy</i>
<i>Poor Temperature Control</i>	<i>No Liquid Circulation</i>	<p><i>Check operation of pump motor (M). Replace motor if not operating.</i></p> <p><i>Check pump operation. Inspect pump/motor coupling. Replace if worn or not functional.</i></p> <p><i>Check for blockages in fluid circulation loop. Disassemble lines and manifold, inspect and clean if needed.</i></p>
	<i>Temperature sensor fowled</i>	<i>Check sensor for cleanliness or contact with other objects. Clean if needed.</i>
	<i>Temperature sensor malfunctioning</i>	<i>Disconnect and check resistance between the red leads and white lead. Values should correspond to specifications in Table Platinum RTD Sensor. If out of specification replace</i>
	<i>Controller malfunctioning</i>	<p><i>Power system down and restart. Check for alarms or errors. Check all parameters match factory settings. If not functioning correctly replace controller</i></p> <p><i>Check that the alarm limits are at least 2 degrees above and below the set point or at factory settings.</i></p>
<i>No Cooling</i>	<i>Failed Compressor Relay (Compressor and fan will not come on)</i>	<i>Check for operation of compressor relay (J2). Check connections, voltage and continuity of contacts. Replace controller if not functioning correctly</i>
	<i>Poor Condenser Cooling Or Compressor Over Temperature/Overload</i>	<p><i>Clean condenser coil. Check for cooling of refrigerant across condenser coil. Repair coil fins if needed.</i></p> <p><i>Check for operation of fan and fan motor. Replace fan assembly if needed.</i></p>
	<i>Inadequate Ventilation</i>	<i>Check for at least 12-inches on all sides of the unit.</i>



<i>Symptom</i>	<i>Possible Cause</i>	<i>Remedy</i>
<i>No Cooling (cont.)</i>	<i>Failed Compressor</i>	<i>Check for operation of compressor. Check for open windings. Replace compressor unit.</i>
	<i>Plugged Capillary Tube</i>	<i>Check refrigeration cycle. If compressor is hot and the evaporator coil (in the reservoir) is not cool there may be a clog in the circuit. Replace evaporator unit.</i>
<i>Interlock Fault</i>	<i>Interlock device open</i>	<i>Check panel interlock switches (S4 and S5) and over-temperature switch (S3). Pull switch to close circuit with panel off.</i>
	<i>Faulty Auxiliary Switch on Main Contactor</i>	<i>Check circuit for continuity when contactor is closed. Controller will wait for 4 seconds to for interlock (J17) to close on start.</i>

<i>Temperature (°C)</i>	<i>Resistance (Ω)</i>	<i>Temperature (°C)</i>	<i>Resistance (Ω)</i>
<i>0</i>	<i>100.0±0.1</i>	<i>55</i>	<i>121.3</i>
<i>5</i>	<i>101.9</i>	<i>60</i>	<i>123.2</i>
<i>10</i>	<i>103.9</i>	<i>65</i>	<i>125.2</i>
<i>15</i>	<i>105.8</i>	<i>70</i>	<i>127.1</i>
<i>20</i>	<i>107.8</i>	<i>75</i>	<i>128.9</i>
<i>25</i>	<i>109.7</i>	<i>80</i>	<i>130.9</i>
<i>30</i>	<i>111.7</i>	<i>85</i>	<i>132.8</i>
<i>35</i>	<i>115.5</i>	<i>90</i>	<i>134.7</i>
<i>40</i>	<i>116.5</i>	<i>95</i>	<i>136.6</i>
<i>45</i>	<i>117.5</i>	<i>100</i>	<i>138.5</i>
<i>50</i>	<i>119.4</i>		

*Table 1.
Platinum RTD Sensor*



8.0 PARTS LIST

Following is a list of commonly replaced parts for the AGT354D. Device labels correspond to the electrical schematic. Call the factory for price and availability.

Table Parts List for the AGT354D

Part Number	Description	Device Label
100081	Caster, Locking	
100082	Caster, Non-locking	
100052	Circuit Breaker, 110V	CB1
100730	Circuit Breaker, 220V	CB1
100595	Compressor/Condenser Assembly 115V, 60Hz	C
100598	Compressor/Condenser Assembly 220V, 50Hz	C
100724	Contactora, 3pole, 220V	PC
100722	Controller, Overlay, AGT354D, 220V	
100742	Controller, UCM Display Board	UCM PB
100735	Controller, UCM Power Board	UCM DB
100603	Evaporator Assembly	
100141	Fitting, Liquid Level Switch	
100155	Fitting, Temperature Sensor	
100117	Fuse Holder Assembly, 110V	F1
100597	Fuse Holder Assembly, 220V	F1
100161	Fuse, 15 Amp (used with 110V units)	F1
100165	Fuse, 8 Amp (used with 220V units)	F1
100057	Ground Loop Clamp, Heater	
100174	Heater, 1500 Watts, 115V	HR1
100175	Heater, 1500 Watts, 220V	HR1
100330	Insulation Tape, Cork	
100228	Latch, Housing Lid	
100218	Lid, Large Phenolic	
100216	Lid, Small Phenolic	
100728	Pressure Sensor, 0-500PSI, 4-20mA	PS
100729	Pressure Snubber, 1/8 NPT, 5 micron	
100233	Pump Motor, 115V 50/60Hz, (Item)	M
100234	Pump Motor, 220V 50/60Hz, (Item)	M
100264	Pump, Circulation, Brass, 2.8 GPM	
100255	Pump/Motor Coupler	
100290	Relay, Solid State	SSR
100726	RTD, 100 Ω 3wire, AGT354D	
100217	Strap, Housing Lid	
100319	Switch, Interlock Safety	S4, S5
100317	Switch, Liquid Level	S7
100320	Switch, Thermal Safety, 50°C	S3
100062	V-Band Clamp	
100725	Wire Harness, Power, AGT354D	
100741	Wire Harness, Sensor, AGT354D	
100751	Fuse, 2.5A, 5x20mm, (used on controller)	FS1



9.0 PARTS REPLACEMENT

R&R Pump/Motor

- *Be sure unit is turned off and disconnected from power source.*
- *Drain reservoir.*
- *Remove the screws holding the back panel and remove.*
- *Disconnect power cord from its connections and place to the side.*
- *Remove hose fittings from the bottom of the fitting mounting plate and the bottom of the reservoir.*
- *Unscrew and remove brackets holding the motor to motor mount.*
- *Remove the motor pump assembly from the unit.*
- *Unscrew V-Band and separate the pump from the motor.*
- *Replace broken part. (Note: If replacing the motor. Remove wiring harness from the old motor to the new one. If replacing the pump. Remove the hoses from the old pump and place them in the new pump. Use thread sealing compound or tape on these threads. Place V-Band between pump and motor and join together. The alignment between the pump and motor must be straight and flush against each other. Screw the V-Band down securely.*
- *Reverse steps with new assembly.*
- *Make certain that the oil ports (on 110V motor) are at a 45-degree angle facing out. Refer to Section 6.1 for maintenance requiring access of these ports.*

R&R Fuse

- *Push and turn the fuse holder cap to remove.*
- *Remove fuse and replace.*
- *Push and turn the fuse holder cap to replace.*



■ **WARRANTY POLICY**

Accurate Gas Control Systems, warrants its product against defects in material or in workmanship, when used under appropriate conditions and in accordance with appropriate instructions for a period of no less than one year from the date of shipment of the product.

Accurate Gas control Systems' sole obligation shall be to repair or replace at AGCS options FOB its plant or locally, without charge, any parts(s) that prove defective within the warranty period, provided the customer notifies AGCS promptly and in writing of any such defect. Compensations for labor by other than AGCS employees or authorized agents will not be AGCS obligation. Parts replacement does not constitute an extension of the original warranty period.

AGCS makes no warranty of merchantability, fitness for a particular purpose, or any other warranty, expressed or implied, as to the design, sale installation or use of its products, and shall not be liable for consequential damages resulting from the use of its products.

While AGCS personnel are available to advise customers concerning general applications of all manufactured products, oral representations are not warranties with respect to particular applications and should not be relied upon if inconsistent with product specifications of the terms stated herein.

In any event, the terms and conditions contained in the AGCS formal sales contracts shall be controlling; and any changes must be in writing and signed by an authorized executive of AGCS.

Defective switches, temperature indicators, heaters, temperature controlling devices, and compressors will be replaced without charge one year from the date of shipment. There will be no charge for labor if the unit is returned to the factory prepaid.

Conditions and qualifications of warranty statement shall prevail at all times.

AGCS will not assume responsibility for unauthorized repairs or failure as a result of unauthorized product modifications, or for repairs, replacement, of modifications negligently or otherwise improperly made or performed by persons other than AGCS employees or authorized representatives.



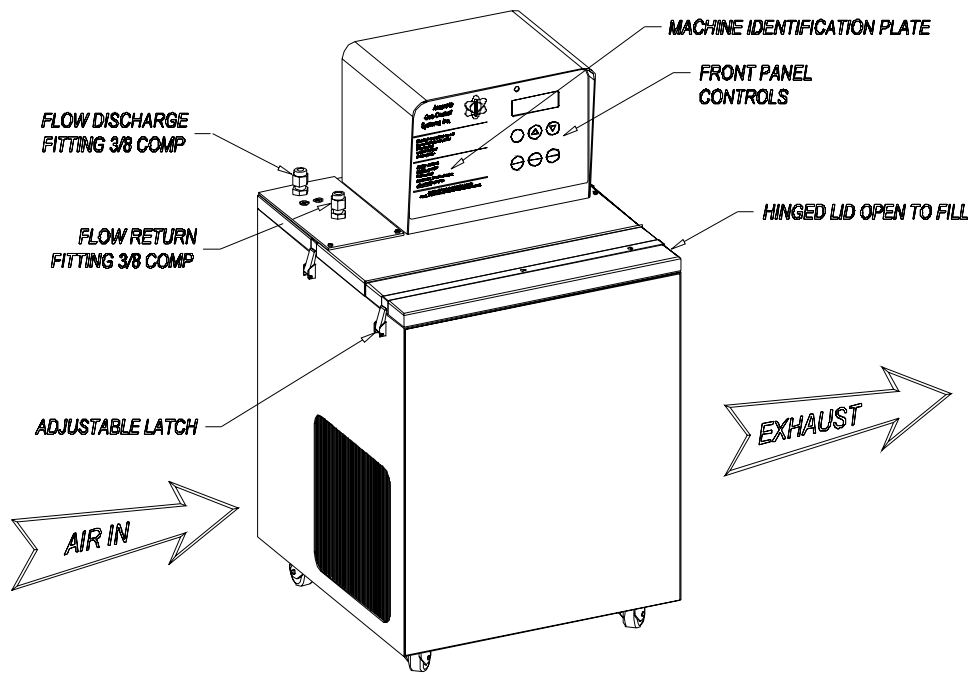

**Front View
Figure 6.**

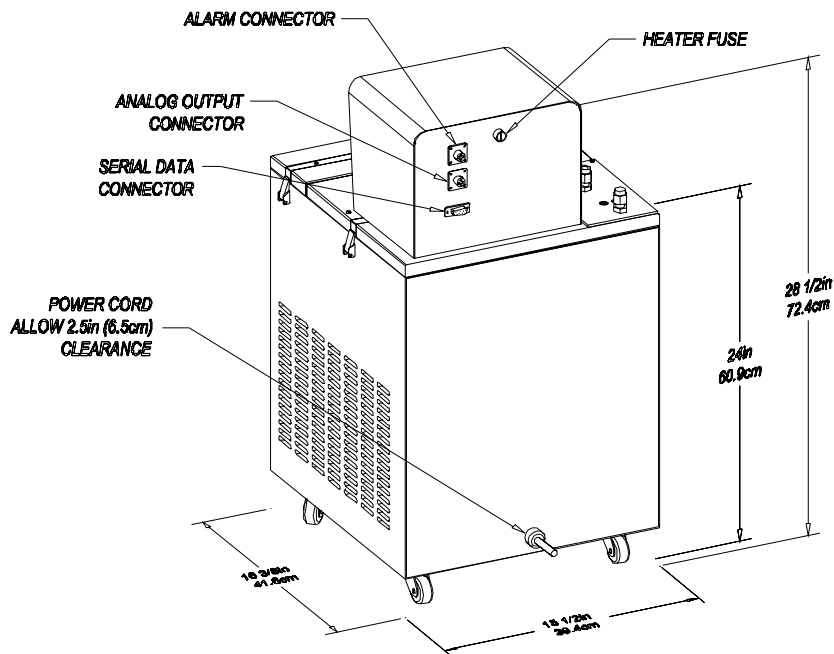

**Back View
Figure 7.**



Revision History

<i>Rev</i>	<i>ECN</i>	<i>Date</i>	<i>By</i>	<i>Description</i>
<i>A</i>	<i>242</i>	<i>6/13/03</i>	<i>CD</i>	<i>Released to Manufacture</i>
<i>B</i>	<i>258</i>	<i>2/2/04</i>	<i>CD</i>	<i>Serial Data and Alarm Connections</i>

