

# ***ACCURATE***

*GAS CONTROL SYSTEMS, Inc.*

*AGT354C*  
*Chiller/Heater Recirculator*  
*Installation and Operation Manual*

*2825 South Rodeo Gulch Rd. • Soquel • California • 95073*  
*PH (831) 462-0500 • FX (831) 462-0507 • [accurategas.com](http://accurategas.com)*

Doc No 30006

## **Table of Contents**

<b>1.0 General Information</b>	<b>2</b>
<b>2.0 Technical Specifications</b>	<b>3</b>
2.1 Mechanical	3
2.2 Electrical	3
<b>3.0 Installation</b>	<b>4</b>
3.1 Electrical Connections	4
3.2 Mechanical Installation	4
3.3 Fluid Connections	5
<b>4.0 Explanation of Controls</b>	<b>5</b>
4.1 Front Panel Controls	5
4.2 Controller	7
4.2.1 Front Panel Controls and Indicators	7
4.2.2 Menu Operation	8
4.2.3 Serial Communication	12
<b>5.0 Operation</b>	<b>14</b>
<b>6.0 Maintenance</b>	<b>15</b>
<b>6.1 Maintenance Schedule</b>	<b>16</b>
<b>7.0 Troubleshooting</b>	<b>17</b>
<b>8.0 Parts List</b>	<b>20</b>
<b>9.0 Parts Replacement</b>	<b>21</b>
<b>10.0 Optional Accessories</b>	<b>22</b>
<b>Warranty Policy</b>	<b>23</b>
<b>Layout Drawings</b>	<b>24</b>
<b>Electrical Schematic</b>	<b>25</b>



## 1.0 GENERAL INFORMATION

The AGT354C Recirculator is a high performance heavy-duty industrial recirculator designed to circulate fluid through a remote system in a closed loop configuration. Temperature control of the remote system is accomplished by a heat exchange process between the system and the recirculator via the circulating fluid. A powerful heater is controlled by a microprocessor based proportional, integral and derivative (PID) controller. Heat is added to the system to modulate the net cooling power of the non-CFC refrigeration system.

A reliable capillary type non-CFC, DuPont's R134a SUVA™, refrigeration system provides the cooling power for the AGT354C Recirculator. This type of refrigeration system is basic in the design and does not employ expansion valves or solenoid switches as in more complicated systems.

Fluid temperature is measured with a platinum resistive thermal device (RTD) sensor. Both the process and set point temperature are clearly displayed on the controller. Temperature control to  $\pm 0.1^{\circ}\text{C}$  is possible based on the accurate RTD input signal, the controller's fast time-based (200ms) output and a large reservoir.

The AGT354C has a 12 Liter (3.2Gallon) reservoir providing a large thermal mass for temperature stability, and thereby, maintaining accurate temperature control of the fluid. The fluid is drained out of the bath into a positive displacement pump. A high torque motor is coupled to a pump for delivering a constant flow rate regardless of the backpressure up to 160 PSI. Pressure regulation of the fluid is achieved by setting the bypass on the pressure regulator manifold (PBM). A liquid filled 0-200 PSI pressure gage on the PBM indicates the backpressure of the entire system. The pump's internal bypass will activate for pressures greater than 160 psi.

The AGT354C has the following features included as standard equipment:

- Adjustable high and low temperature alarms. Settings are accessible on the controller and red LED's indicate an alarm condition.
- A standard latching  $50^{\circ}\text{C} \pm 4^{\circ}\text{C}$  thermal safety switch ( $90^{\circ}\text{C} \pm 4^{\circ}\text{C}$  switch available upon request) with a blue "High Limit" light to indicate the alarm condition.
- A blue "Low Level" light to indicate a low fluid level condition in the reservoir.
- A 2.8-gallon per minute positive displacement circulation pump

The AGT354C also has optional equipment available:

- No-flow alarm
- Sonalert™ audible alarm
- 4-20mA output for remote temperature monitoring
- Serial communications packages for remote system interface and remote temperature monitoring via the controller's RS 232/485 digital output.



## 2.0 TECHNICAL SPECIFICATIONS

### 2.1 Mechanical

Temperature Range:	
	<i>Standard</i> 0°C to 50°C (32°F to 122°F)
	<i>Optional</i> 0°C to 90°C (32°F to 194°F)
Temperature Control System:	Digital Controller, PID
Display Resolution:	±0.1°C (±0.2°F)
Temperature Sensor:	100Ω Platinum 3-wire RTD
Cooling Capacity [20.0°C (68°F)ambient]:	250 Watts (938 BTU/hour) @ 4.0°C (39.2°F)
	675 Watts (2300 BTU/hour) @ 20.0°C (68°F)
Maximum Flow Rate:	9.8 LPM (2.8 GPM)
Refrigerant:	DuPont R-134a SUVA™, non-CFC 5.5oz for 110V 1/4hp units 6.5oz for 220V 1/3hp units
Reservoir Capacity:	12 Liters (3.2 Gallons)
Dimensions, H x W x D:	73 x 42 x 42 cm (28.5" x 16.5" x 16.5")
Weight:	58 kg (127 lbs.)

### 2.2 Electrical

Electrical Specifications		
Model	AGT354C-1	AGT354C-2
Voltage	115 ± 10 Volts	230 ± 20 Volts
Frequency	60 Hz	50 Hz
Phase	Single	Single
Maximum Power Consumption	2875 Watts	2875 Watts
Circuit Requirements	115V, 30A, 1Ph, 60Hz	230V, 15A, 1Ph, 50Hz
Connection	NEMA L5-30P plug	Not supplied



## **3.0 INSTALLATION**

### **3.1 Electrical Connections**

*The customer is responsible for supplying the correct electrical circuit and receptacle for operating the AGT354C Recirculator. Have a qualified electrician check the circuit for proper size, grounding, and electrical connection.*

**Model AGT354C-1 operates on 115 Volt, single phase, 60Hz and comes equipped with a 3-pin, 30A, 120V, NEMA type L5-30P plug.**

**Model AGT354C-2 operates on 230 Volt, single phase, 50 HZ.** *The customer must supply the electrical plug due to the various electrical receptacle configurations in different countries. The AGT354C-2 should be plugged into an electrical circuit that is rated for 230V, 20A, 1Ph and 50Hz.*

**Warning: Do not, under any circumstances, remove the ground pin from the power cord or use a two-pin adapter. Make sure that AGT354C is properly grounded.**

### **3.2 Mechanical Installation**

*Find a solid and level surface able to support the weight (127 lbs., 58 Kg) of the AGT354C recirculator. Four casters are mounted to the AGT354C to conveniently move the unit to the desired location. Use a floor mounted bracketing to brace the AGT354C recirculator if the location is subject to movement.*

*The most stable and uniform performance will be obtained by locating the AGT354C recirculator in an area remote from drafts, ventilation outlets, radiators, and other rapidly changing ambient conditions. Allow at least a 12" space around the AGT354C to assure proper ventilation.*

**Do not place AGT354C recirculators next to each other** unless panels are placed between them to divert the hot exhaust from the left unit entering the intake of the right side unit. *The condenser coil is located on the left side of the unit where air enters and flows across the coil to remove heat. The condenser coil should never be blocked and must be free of dirt and dust for proper and efficient cooling performance.*



### 3.3 Fluid Connections

The AGT354C has ¼" female NPT discharge and return fluid connections on the pressure bypass manifold (PBM) located on the upper left side. The discharge port is located on the far side of the PBM opposite the pressure gage.

All required fittings and tubing are supplied if the AGT354C is supplied with an AG106 Single Connection Kit or AG108 Dual Connection Kit as part of an AG-System. Close proximity of the AGT354C to the system, and insulating the remote plumbing lines improves temperature control. The AGT354C should be located close to the system to be controlled to minimize the length of tubing required, and thereby, reducing the back pressure. The user is responsible for providing appropriate extension tubing able to handle the application temperature and pressures for the systems. Suitable tubing sizes are 3/8" and ½".

AG-106 SINGLE JACKET CONNECTION KIT

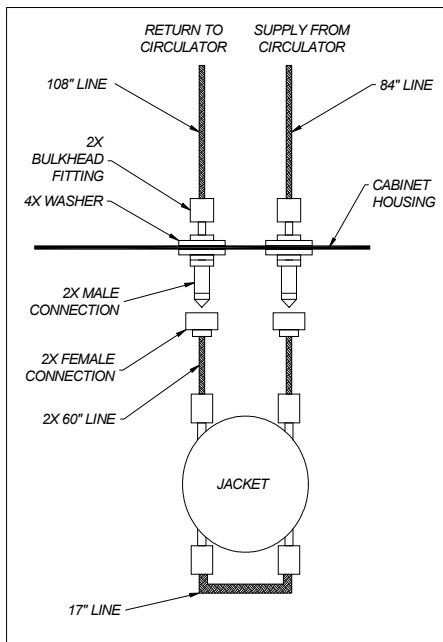

AG-108 DUAL JACKET CONNECTION KIT

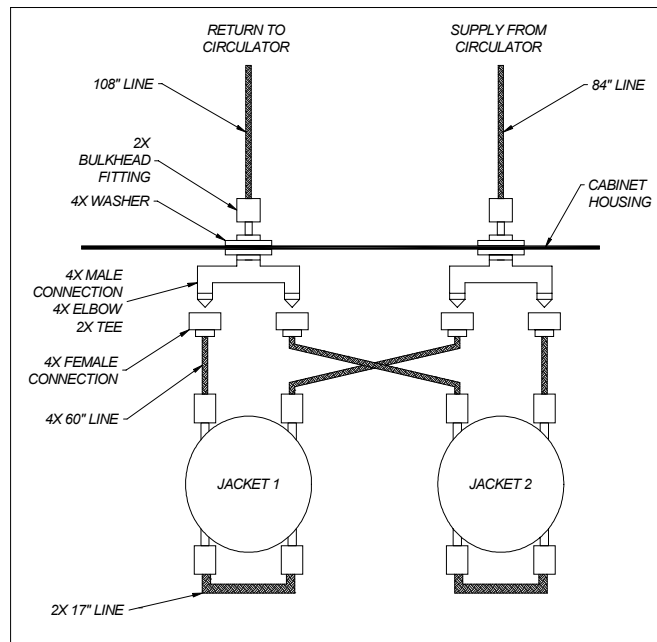

## 4.0 EXPLANATION OF CONTROLS

### 4.1 Front Panel Controls

#### Power Circuit Breaker Switch:

Located on the upper rear corner of the right panel a circuit breaker switches all the electrical power to the unit. In the event of a current surge, the breaker will trip and cut the electrical power to the unit to protect personnel and sensitive items. The unit needs to be restarted manually in case the circuit breaker is tripped.

#### Fuse:

The heating circuit of the AGT354C is protected with a fuse. The fuse holder is located on the back of the upper housing. A 15A, 250V fuse is used in the AGT354C-1 (110V) unit. An 8A, 250V fuse is used in the AGT354C-2 (220V) unit.

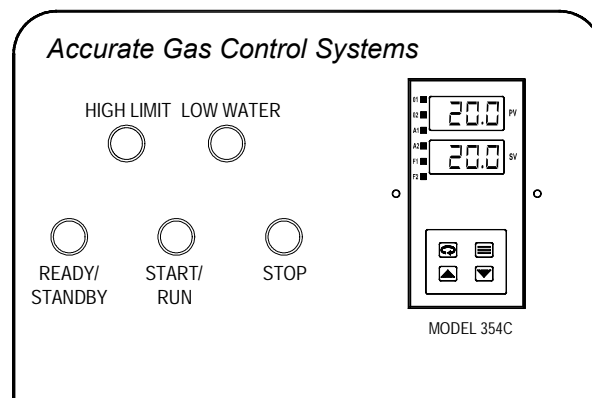

#### High Limit:

The blue High Limit light will illuminate when the recirculator reaches  $50^{\circ}\text{C}$  ( $122^{\circ}\text{F}$ )  $\pm 4^{\circ}\text{C}$  (optional units limit at  $90^{\circ}\text{C}$  ( $194^{\circ}\text{F}$ )  $\pm 4^{\circ}\text{C}$ ). The light indicates an over-temperature condition and the unit is shut down in a latched reset mode. Once the high-temperature condition has cleared, the yellow Reset/Standby switch will become illuminated.

#### Low Water:

The Low Water light will illuminate when the reservoir water level is below the required level for proper operation. Fill the reservoir to within 1.5" from the upper rim and the light will clear.

#### Reset/Standby

The yellow Reset/Standby switch will illuminate when the unit is ready for operation. Standby mode occurs when the circuit breaker switch is in the On position or when the Stop switch has been pressed. Reset mode occurs after the high limit over-temperature condition has cleared. The switch needs to be pressed before the unit can be started. The Reset/Standby push button will not illuminate after the switch has been pressed.

#### Start/Run

The green Start/Run switch energizes the recirculator after it is pressed. The switch will illuminate when the unit is operating.

#### Stop

The recirculator is de-energized when the red Stop switch is pressed.



## 4.2 Controller

The microprocessor-based controller has both the process temperature and setpoint temperature displayed. The setpoint is easily adjusted by pressing on the **Raise** ▲ and **Lower** ▼ pads on the face of the controller. Prolonged depression of the **Raise** ▲ and **Lower** ▼ keys changes the values at an accelerated rate, while unitary digital changes are accomplished by individual depression of the pads. The AGT354 has been configured for operation from the factory.

### 4.2.1 Front Panel Controls and Indicators

01 Indicator = Output 1, preset from factory

The 01 indicator will illuminate when heat is applied to the system by the controller.

02 Indicator = Output 2, preset from factory Output 2 is not used.

A1 Indicator = Alarm 1, preset from factory at 50°C

The A1 indicator will illuminate if a high temperature condition has occurred.

A2 Indicator = Alarm 2, preset from factory at 1.5°C

The A2 indicator will illuminate if a low temperature condition has occurred.

Parameter Access Key ↻ allows access to the menu level functions

Mode/Enter Key ≡ allows access to different modes or the return to the current mode from the menu mode.

Raise Key ▲ increases the parameter value or setpoint temperature

Lower Key ▼ decreases the parameter value or setpoint temperature.

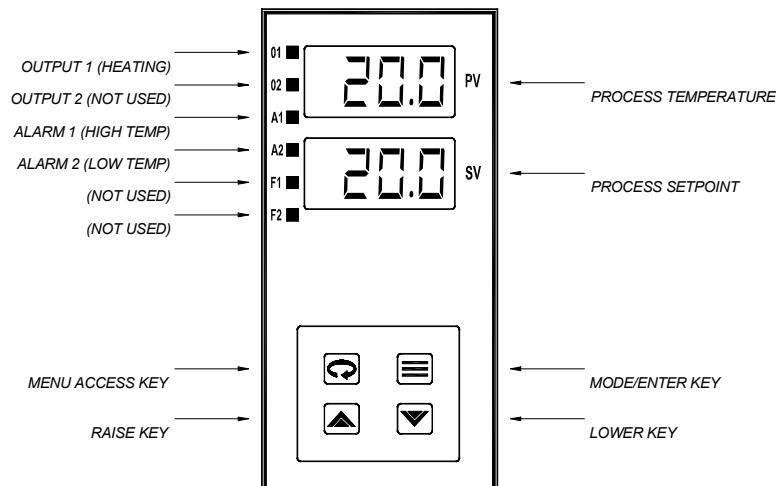

Figure 1  
Controller Display and Indicators





PV = Process Value Display

A time filtered, display of the process temperature and error codes

SV = Setpoint Value Display

Displays the current temperature setpoint. Menu levels and values appear on the SV display when in menu mode. Percent of output is displayed when in manual mode.

4.2.2 Menu Operation

The microprocessor menu system is divided into 4 levels shown in Figure 2. The Process Variable Display level is active during normal operation and shows the setpoint and process temperature. The Mode Selection level is used to force the controller into various operating modes. The Security Level is used to select the extent of operator access to system parameters. The Parameter Menu System level is organized in submenus which are used to adjust the configuration and operation parameters of the controller. Following is a detailed discussion of these four menu levels.

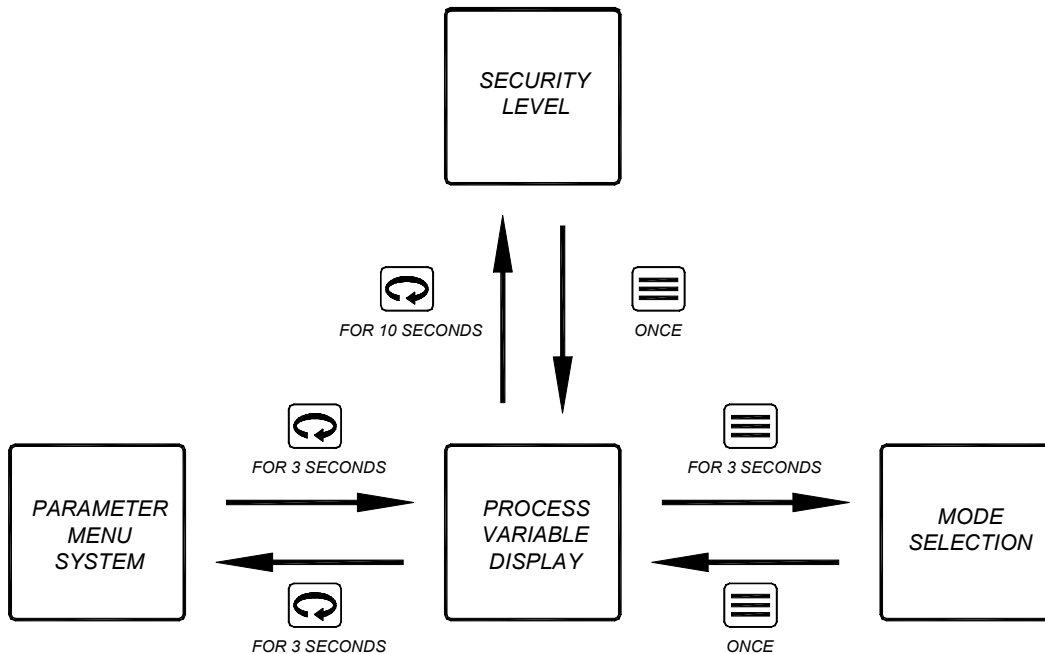





Figure 2  
Menu System Overview

Process Variable Display

The Process Variable Display is active during normal system operation. From this level the setpoint can be adjusted and the temperature can be observed. All other menu levels are accessible from the Process Variable Display level. To adjust the setpoint use the **Raise** ▲ and **Lower** ▼ keys. All other menu levels can be accessed using various combinations of the **Mode/Enter** ≡ key and the **Menu Access** ↻ key.





### Mode Selection

The operating mode can be setup and adjusted using parameters in the Mode Selection level. The Mode Selection level can be accessed from the Process Variable Display level by depressing the **Mode/Enter**  key for 3 seconds. Once in the Mode Selection level the controller will display one of the following codes. Use the **Raise**  key to change modes. Depress the **Mode/Enter**  key to select a mode and return to the Process Variable Display level. Following is an explanation of the different levels and how each one operates. The unit will be shipped in the NOR Mode Selection.

Code	Mode	Description
<i>FOP</i>	Manual	Used to manually force an output independent of Process Value. Once in this mode the <i>PRCT</i> menu will appear in the Menu System level. The <i>PCT1</i> and <i>PCT2</i> can be adjusted for output 1 and output 2. The output will be in 0 to 100% of full load.
<i>STBY</i>	Standby	Used to disable control outputs
<i>NOR</i>	Normal	Normal automatic control
<i>ATUN</i>	Autotune	Used to initiate the autotuning sequence (from the Standby Mode only)
<i>R.5</i>	Ramp/Soak	Used to start ramp/soak recipe mode
<i>R5.R</i>	Run (recipe)	Used to enable the Run function
<i>R5.H</i>	Hold (recipe)	Used to enable the Hold function







### Security Level

The security feature allows the user to limit the access to the menus, setpoint and operating mode selection according to the needs of the application. The Security Level can be accessed by depressing the **Menu Access**  key for 10 seconds. Once in the Security level the controller will display one of the following codes. Use the **Raise**  key to change modes. Depress the **Mode/Enter**  key to select a mode and return to the Process Variable Display level. Following is an explanation of the different levels and how each one operates. The unit will be shipped in the USER Security Mode.

Code	Mode	Description
<i>LOC.0</i>	Key Lockout	Highest security level. No access to any controller function. The controller will only respond to a change in security mode.
<i>SP</i>	Setpoint	Only allows access to Setpoint value (output percentage in manual mode)
<i>SP.PL</i>	Setpoint Plus Mode	Only allows access to Setpoint value and Operating Mode
<i>USER</i>	User	Allows access to Setpoint, Operating Mode, Autotune and Control Menus.
<i>CNF9</i>	Configuration	All user privileges as well as Input, Output, Display, and Supervisor menus
<i>FACT</i>	Factory	Full access



## Parameter Menu System

The Parameter Menu System level is organized into ten basic menus. Each menu within this level contains logical groups of system variables and configuration parameters. To access the Parameter Menu System level depress the **Menu Access**  key for 3 seconds. Once in the Parameter Menu System level the controller will display a Menu Code in the **PV** display window. Use the **Mode/Enter**  key to index through the parameters in the current menu. Use the **Raise**  and **Lower**  keys to adjust parameters. Use the **Mode/Enter**  key enter an adjustment. To exit the Parameter Menu level depress the **Menu Access**  key for 3 seconds. Following is an explanation of the menus and parameters in the Parameter Menu System level. The unit will be programmed with the Factory Settings. The order in which changes are made in the menu system may effect parameter settings. Follow the order of the table for best results.

Code	Factory Setting	Description	Range
<b>DSPL</b>		<b>Display Menu</b>	
DEC.P	1	Decimal position	0 to 1
D.FIL	0.1	Display filter	0.1 to 10 sec
UNIT	C	Engineering Units	C, F or K
BLAN	OFF	Blanking	0 to 9999 sec
<b>INP</b>		<b>Input Menu</b>	
TYPE	RT.D	Input type is 100Ω Platinum RTD	
BIAS	0.0	Input bias	-100 to 100
SPLL	1.5	Lower setpoint limit	Span of sensor
SPHL	50.0	Upper setpoint limit	Span of sensor
I.FIL	2.0	Input filter	0.1 to 10 sec
<b>OUTP</b>		<b>Output Menu</b>	
01.TY	PID	Output 1 type	
01.AC	RE	Output 1 action	
01.CY	0.2	Output 1 cycle time	0.2;1 to 120 sec
01.LL	0	Output 1 low limit	1 to 100%
01.HL	100	Output 1 high limit	1 to 100%
02.TY	PID	Output 2 type	
02.AC	RE	Output 2 action	
02.CY	0.2	Output 2 cycle time	0.2;1 to 120 sec
02.LL	0	Output 2 low limit	1 to 100%
02.HL	100	Output 2 high limit	1 to 100%
<b>CTRL</b>		<b>Control Menu</b>	
PBI	1.9	Proportional band 1	1 to sensor span
DER	48	Derivative rate	0 to 2400 sec
OFFS	OFF	Manual reset	-100% to 100%
INT	24I	Integral reset	0 to 9600 sec

Code	Factory Setting	Description	Range
<b>ALR</b>		<b>Alarm Menu</b>	
A1.AA	NOR	Alarm 1 action	
A1.AO	PRO.H	Alarm 1 operation	
A1.DL	0	Alarm 1 delay	0 to 9999 sec
A1.IH	0	Alarm 1 inhibit	0 to 9999 sec
A1.SP	50	Alarm 1 setpoint	0 to sensor span
A2.AA	NOR	Alarm 2 action	
A2.AO	PRO.L	Alarm 2 operation	
A2.DL	0	Alarm 2 delay	0 to 9999 sec
A2.IH	0	Alarm 2 inhibit	0 to 9999 sec
A2.SP	1.5	Alarm 2 setpoint	0 to sensor span
<b>TUNE</b>		<b>Autotune Damping Menu</b>	
DPN9	NL	Damping normal	
<b>R-5</b>		<b>Recipe Ramp/Soak Menu</b>	
R.OPT	DIS	Option disabled	
<b>SUPR</b>		<b>Supervisor Menu</b>	
F.S.01	0	Failsafe state 1	0 to 100%
F.S.02	0	Failsafe state 2	0 to 100%
L.BR.T	OFF	Loop break time	4 to 9600 sec
HI.RD	Read only	Highest reading	
LO.RD	Read only	Lowest reading	
LD.DP	NO	Load default parameters	
<b>CAL</b>		<b>Calibration Menu</b>	
CALO	0	Low value	
CAHI	768.0	High Value	
<b>OPTN</b>		<b>Options Menu</b>	
CARD	NONE	Card Option – no card installed	



### 4.2.3 Serial Communication

The AGT354C Controller has serial communications available for interface with plant SCADA systems or other machine interfaces. Currently there are three types of connections and two data protocols available. Each option has different benefits and devices for connection. Accurate Gas Control Systems recommends that each option be carefully studied and considered before integration. Many new products available today allow the controller to be connected to just about any industrial host. Following is a synopsis of available options. Please consult the factory for ordering and detailed information. Special instructions are available for each option and are available upon request.

#### Remote Communication Options

Three serial communication options are available: RS-232, RS-422 and RS-485. The controller can be configured for any of these options from the factory. Data converters are also available if required. Each option has different wiring requirements.

##### RS-232

RS-232 method allows bidirectional data transfer via a three-conductor cable consisting of signal ground, receive input and transmit output. It is recommended for communication distances less than 50 feet between the computer terminal and the instrument. Multiple instruments can not be connected to the same port.

##### RS-422

RS-422 method allows bidirectional data transfer via a four-wire conductor cable for distances over 4000 feet between the computer terminal and the instrument. A signal ground is not required.

##### RS-485

RS-485 method allows bidirectional data transfer over a twisted pair conductor. Instruments may be connected to the computer terminal in parallel or series. Termination resistors at the last instrument are required for series connections. RS-485 connections have multi-point capability up to 32 instruments in a duplex network or up to 100 instruments with a repeater.

## Serial Communication Protocol

The AGT354C has two serial data protocols available - Athena+™ and Modbus™. Detailed information on these protocols is not in the scope of this manual. Please consult the factory for detailed information. Following is a brief explanation of each protocol option.





### Athena+™ Protocol and Multi-com™ Interface Software

The Athena +™ Protocol and Multi-com™ Software are proprietary products of Athena Controls Incorporated. These products have been developed especially for the Athena product line. Multi-com™ is an integrated software product that allows the user to query and command a controller in a developed “point and click” environment. The Multi-com™ product is a stand-alone “plug and play” program that has many advanced features for process data acquisition and control. Multi-com™ uses the Athena+™ Protocol to send and receive messages from the host computer to the controller. The Athena+™ Protocol uses a string of printable ASCII characters to transfer request and response messages from the host computer to the controller. A host computer can communicate with one or several units. Other host software programs that can generate and read serial data script can be used to communicate with controllers using the Athena+™ Protocol. Consult the factory for detailed information regarding these products.

### Modbus™ Protocol

The Modbus™ Protocol is a registered trademark of AEG Schneider Automation, Incorporated. The Modbus™ Protocol is widely used in industry and is compatible with many AEG Schneider Automation products. This protocol option allows the controller to be connected to a wide range of devices, but will require more advanced integration. Consult the factory for detailed information regarding these products.

## 5.0 OPERATION

- 5.1 Plug the AGT354C into an appropriate electrical receptacle. Check the serial plate for power requirements on your unit or refer to Section 3.1 Electrical Connections. A circuit rated for 30 Amp, 120 Volt, 60 Hz will be required for the AGT354C-1. A circuit rated for 20 Amp, 230 Volt, 50 Hz will be required for the AGT354C-2.
- 5.2 Unlatch and lift the front lid and pour Thermex™ into the reservoir. Fill the reservoir to within 1-½ inches from the upper rim of the reservoir.
- 5.3 Switch the circuit breaker, located on the right upper rear side, to the ON position. The yellow Reset/Standby button should now be illuminated.
- 5.4 If the blue Low Level indicator light is illuminated add more Thermex™.
- 5.5 Set the discharge valve on the pressure bypass manifold to the OPEN position. The green valve lever will be in the vertical position when open.
- 5.6 Depress the Reset/Standby switch and then the Start switch. The unit will come on and begin to pump Thermex™ and control the process.
- 5.7 Check the level in the reservoir. Additional fluid may be needed as the jackets and lines fill. If the blue Low Level indicator light is on add more Thermex™. Fill the reservoir to within 1 ½-inches from the upper rim of the reservoir.
- 5.8 Check the supply pressure on the pressure bypass manifold (PBM). The pressure should be lower than 100 PSI and never greater than 120 PSI. An operating pressure of 30 PSI to 60 PSI will work well for most applications. To increase the bypass pressure turn the knurled knob, on top of the PBM, clockwise. Lower operating pressure will prolong the life of the pump and motor.
- 5.9 Set the desired operating temperature on the controller. Use the **Raise** ▲ and **Lower** ▼ keys to adjust the temperature shown in the **SV** window in degrees Celsius. Allow the unit to reach the set point. It may take several minutes for the system to settle
- 5.10 Adjust the High and Low Temperature alarm limits to the process temperature.
  - Depress the **Menu Access**  key for 3 seconds to enter the Parameter Menu System.
  - Depress the **Menu Access**  key 5 times or until the display shows **ALR**
  - Depress the **Mode/Enter**  key 5 times or until the display shows **AISP**
  - Use the **Raise** ▲ and **Lower** ▼ keys to adjust value to **3 °C above the setpoint**.
  - Depress the **Mode/Enter**  key 6 times or until the display shows **A2SP**
  - Use the **Raise** ▲ and **Lower** ▼ keys to adjust value to **3 °C below the setpoint**.
  - Depress the **Menu Access**  key for 3 seconds to exit the Parameter Menu System.



## 6.0 MAINTANANCE

Regular maintenance of the AGT354C will provide years of trouble free performance. Below is a list of major components that should be checked and maintained followed by a detailed maintenance schedule.

### Pump Motor

A carbonator motor drives the recirculation pump. With constant usage the motor will need lubrication every 6 months. Remove the back lower panel to the AGT354C to gain access to the pump motor. Two oil ports are located on the upper side of the motor. The ports are capped with small yellow plugs. Remove the plugs and drip 15 drops of SAE 20 motor oil into each port. Replace the caps when complete.

### Condenser Fins

The refrigeration system of the AGT354C is an air-cooled, non-CFC, condensing unit. Air is drawn into the unit across the condenser coils. The condenser coil is located on the left side of the unit. The airflow through the coil removes heat from the system. For efficient and proper cooling it is imperative to keep the coils free of obstruction such as dirt and lint. Use a vacuum cleaner, air hose or a brush to remove the debris collected on the fins. Be careful not to damage the condenser fins.

### Reservoir

Changing the fluid occasionally will prevent mildew growth and remove particulate that can damage the pump. A change of fluid once a year is recommended. More frequent changes may be required depending on the application. The frequency of changing the fluid depends of the degree of growth and cleanliness. Warmer operation temperatures promote algae and mildew buildup, therefore, a more frequent fluid changes is recommended. An algaecide may be added to the fluid to prevent algae. Use the following procedure to drain the reservoir.

- Set the operating temperature to 0° C
- Disconnect the return line on the manifold and place a bucket underneath the tubing.
- Press the green Start/Run switch and allow the pump to empty the reservoir. When the reservoir is empty press the red Stop switch to stop the pump. **Do not let the pump run dry for more than 30 seconds.**





## 6.1 Maintenance Schedules

Following is a schedule of preventative maintenance inspections and procedures to be performed for the maximum performance and useful service life from your recirculator. In case of malfunctions, refer to Section 7 Troubleshooting.

### **Every Month**

- Lift the reservoir lid and check the fluid level. The fluid level should be within 1 ½-inches of the rim. Add fluid as required. If the fluid level is low, not within 3-inches of the rim, check the unit for leaks.
- While the unit is running, lift the reservoir lid and make sure that fluid is circulating.
- Clean the condenser coil on the left side of the unit.
- Check for airflow through the unit. A fan mounted behind the condenser draws air through the unit.
- Check the controller display for set point and operating temperature. The unit should display an operating temperature, on the PV display, within  $\pm 0.1^{\circ}$  C of the set point on the SV display.
- Check for alarm conditions on the controller. If an alarm condition exists the A1 or A2 indicators on the front panel of the controller will illuminate.

### **Every 6 Months**

- Perform all monthly maintenance inspections and service.
- Lubricate pump motor with 30 drops of SAE 20 nondetergent oil. Put 15 drops in each of the oiling portholes, which are located on the topsides of the motor. The oiling ports are plugged with yellow removable caps<sup>1</sup>.
- Lift the reservoir lid and inspect the fluid cleanliness. If there is dirt or buildup in the reservoir it should be cleaned and the fluid should be replaced. Always use Thermex™ fluid in the AGT354C.

### **Every 12 Months**

- Perform all monthly and 6 month inspections and service.
- Inspect the motor and pump shaft coupling. Remove the back panel of the AGT354C. Loosen the V-Band clamp holding the pump to the motor. Pull the pump away from the motor and check for wear on both shafts. Look for the presence of a dark powder. If the shafts look intact and show little wear reinstall the pump. Make certain the pump flange is flush with the motor flange and that the shafts are lined up. Tighten the V-Band clamp, replace the back panel, and run the unit checking for circulation.

1.) 220V units do not have oil service ports. Disregard this service on 220V units.



## 7.0 TROUBLESHOOTING

**WARNING:**

*A qualified technician should perform service. Before attempting service on any part of the unit disconnect the power cord. If service is required with the unit running use caution.*

**A CERTIFIED REFRIGERATION TECHNICIAN**

*should perform Service of refrigeration equipment. If problems can not be resolved call the factory for technical support or service.*

<i>Symptom</i>	<i>Possible Cause</i>	<i>Remedy</i>
<i>No power to circulator</i>	<i>External main fuse blown or circuit breaker tripped</i>	<i>Replace main fuse, reset breaker or overload</i>
	<i>Loose line cord terminals</i>	<i>Secure power cord</i>
	<i>Cover interlock switches not made or malfunctioning</i>	<i>Check (2) interlock switches (S4 and S5)</i>
<i>No heat (Run away cooling)</i>	<i>Blown or damaged fuse</i>	<i>Check fuse and replace if blown (F1). Use 8 AMP fuse for 220V units or 15 AMP fuse for 115V units.</i>
	<i>Failed Heater</i>	<i>Check heater (HR1). Disconnect and check resistance between poles. Resistance values should be <math>9.6\Omega \pm 10\%</math> for 115V units or <math>32.3\Omega \pm 10\%</math> for 220V units. Resistance to ground should be greater than 100,000<math>\Omega</math>. Replace if not in specification.</i>
	<i>Failed Relay</i>	<i>Check relay (SSR1). Check for 24VAC on the poles 3 and 4. If present, check for voltage on poles 1 and 2. Replace if no output on pole 2.</i>
	<i>Failed Controller</i>	<i>Power system down and restart. Check that set point is higher than process temperature. If true, then output 1 indicator will illuminate. If illuminated check for output voltage on pins 1 and 2 (device A1). If not functioning correctly replace controller (A1)</i>



<i>Symptom</i>	<i>Possible Cause</i>	<i>Remedy</i>
<i>Continuous heat (Run away heating)</i>	<i>Failed Temperature Sensor</i>	<p>Check sensor (RTD) wire connections 18, 19 and 20 on the controller (A1).</p> <p>Disconnect and check resistance between the red leads and white lead. Values should correspond to specifications in Table Platinum RTD Sensor. If out of specification replace sensor.</p>
	<i>Failed Relay</i>	<p>Check relay (SSR1). Check for 24VAC on the poles 3 and 4. If not present, check for voltage on poles 1 and 2. Replace if output on pole 2.</p>
	<i>Failed Controller</i>	<p>Power system down and restart. Check that set point is lower than process temperature. If true, then output 1 indicator will not illuminate. If not illuminated check for output voltage on pins 1 and 2 (device A1). If not functioning correctly replace controller (A1)</p>
<i>Poor Temperature Control</i>	<i>No Liquid Circulation</i>	<p>Check operation of pump motor (B1). Replace motor if not operating.</p> <p>Check pump operation. Inspect pump/motor coupling. Replace if worn or not functional.</p> <p>Check for blockages in fluid circulation loop. Disassemble lines and manifold, inspect and clean if needed.</p>
	<i>Temperature sensor fowled</i>	<p>Check sensor for cleanliness or contact with other objects. Clean if needed.</p>
	<i>Temperature sensor malfunctioning</i>	<p>Disconnect and check resistance between the red leads and white lead. Values should correspond to specifications in Table Platinum RTD Sensor. If out of specification replace</p>



	<i>Controller malfunctioning</i>	<i>Power system down and restart. Check for alarms or errors. Check all parameters match factory settings (see Section 4.2.2). If not functioning correctly replace controller (A1)</i>  <i>Check that the alarm limits are at least 2 degrees above and below the set point or at factory settings.</i>
<i>No Cooling</i>	<i>Failed Compressor Relay (Compressor and fan will not come on)</i>  <i>Poor Condenser Cooling Or Compressor Over Temperature/Overload</i>  <i>Inadequate Ventilation</i>  <i>Failed Compressor</i>  <i>Plugged Capillary Tube</i>	<i>Check for operation of compressor relay (K3). Check connections, voltage and continuity of coil and contacts. Replace if not functioning correctly</i>  <i>Clean condenser coil. Check for cooling of refrigerant across condenser coil. Repair coil fins if needed.</i>  <i>Check for operation of fan and fan motor. Replace fan assembly if needed.</i>  <i>Check for at least 12-inches on all sides of the unit.</i>  <i>Check for operation of compressor. Check for open windings. Replace compressor unit.</i>  <i>Check refrigeration cycle. If compressor is hot and the evaporator coil (in the reservoir) is not cool there may be a clog in the circuit. Replace evaporator unit.</i>

*Table Platinum RTD Sensor*

<i>Temperature (°C)</i>	<i>Resistance (Ω)</i>	<i>Temperature (°C)</i>	<i>Resistance (Ω)</i>
0	100.0±0.1	55	121.3
5	101.9	60	123.2
10	103.9	65	125.2
15	105.8	70	127.1
20	107.8	75	128.9
25	109.7	80	130.9
30	111.7	85	132.8
35	115.5	90	134.7
40	116.5	95	136.6
45	117.5	100	138.5
50	119.4		

## 8.0 PARTS LIST

Following is a list of commonly replaced parts for the AGT354C. Device labels correspond to the electrical schematic. Call the factory for price and availability.

Table Parts List for the AGT354C

Part Number	Description	Device Label
100315	Auxiliary Switch, Power Contactor	K2
100223	Blue Round Lens	DS3
100081	Caster, Locking	
100082	Caster, Non-locking	
100052	Circuit Breaker, 110V	CB1
100053	Circuit Breaker, 220V	CB1
100595	Compressor/Condenser Assembly 115V, 60Hz	M1
100598	Compressor/Condenser Assembly 220V, 50Hz	M1
100229	Controller, Microprocessor	A1
100603	Evaporator Assembly	
100141	Fitting, Liquid Level Switch	
100155	Fitting, Temperature Sensor	
100117	Fuse Holder Assembly, 110V	F1
100597	Fuse Holder Assembly, 220V	F1
100161	Fuse, 15 Amp (used with 110V units)	F1
100165	Fuse, 8 Amp (used with 220V units)	F1
100224	Green Square Lens	S6
100057	Ground Loop Clamp, Heater	
100174	Heater, 1500 Watts, 115V	HR1
100175	Heater, 1500 Watts, 220V	HR1
100222	Incandescent Lamp, 24V	DS7, DS3, XDS2, XDS6
100330	Insulation Tape, Cork	
100319	Interlock Safety Switch	S4, S5
100218	Large Phenolic Lid	
100228	Latch, Housing Lid	
100221	Light Body, Round	DS3, DS7
100317	Liquid Level Switch	S7
100048	Power Contactor	K2
100244	Pressure Gage, 0-200 PSI	
900009	Pressure Regulator Manifold Assembly (PBM)	
100233	Pump Motor, 115V 50/60Hz, (Item)	B1
100234	Pump Motor, 220V 50/60Hz, (Item)	B1
100264	Pump, Circulation, Brass, 2.8 GPM	
100255	Pump/Motor Coupler	
100225	Red Square Lens	S1
100288	Relay, DPDT, 24V	K1, K3, K4
100290	Relay, Solid State	SSR1
100216	Small Phenolic Lid	
100217	Strap, Housing Lid	
100414	Switch Body, Square	S1, S2, S6
100314	Switch Element	S1, S2, S6
100320	Switch, Thermal Safety, 50°C	S3
100321	Switch, Thermal Safety, 90°C (Optional)	S3
100299	Temperature Sensor, RTD	RTD
100352	Transformer, Dual Pole, 115-220V/24V	T1
100062	V-Band Clamp	
100173	Wire Harness	
100226	Yellow Square Lens	S2



## 9.0 PARTS REPLACEMENT

### *R&R Pump/Motor*

- *Be sure unit is turned off and disconnected from power source.*
- *Drain reservoir.*
- *Remove the screws holding the back panel and remove.*
- *Disconnect power cord from its connections and place to the side.*
- *Remove hose fittings from the bottom of the PBM block and the bottom of the reservoir.*
- *Unscrew and remove brackets holding the motor to motor mount.*
- *Remove the motor pump assembly from the unit.*
- *Unscrew V-Band and separate the pump from the motor.*
- *Replace broken part. (Note: If replacing the motor. Remove wiring harness from the old motor to the new one. If replacing the pump. Remove the hoses from the old pump and place them in the new pump. Use thread sealing compound or tape on these threads. Place V-Band between pump and motor and join together. The alignment between the pump and motor must be straight and flush against each other. Screw the V-Band down securely.*
- *Reverse steps with new assembly.*
- *Make certain that the oil ports (on 110V motor) are at a 45-degree angle facing out.*

### *R&R Fuse*

- *Push and turn the fuse holder cap to remove.*
- *Remove fuse and replace.*
- *Push and turn the fuse holder cap to replace.*



## **10.0 OPTIONAL ACCESSORIES**

*The following accessories are available upon request. Contact the factory for further information, price and availability.*

- *Audible Alarm – This alarm will alert the operator if any alarm condition occurs.*
- *Temperature Signal Output – This 4-20mA analog output is designed for use with remote display equipment or monitoring equipment.*
- *No-Flow Safety Switch – This safety switch will shut the unit down in the event of a no flow condition.*
- *90°C Thermal Safety Switch – This switch allows the unit to operate at higher temperatures than standard.*

## **WARRANTY POLICY**

*Accurate Gas Control Systems, warrants its product against defects in material or in workmanship, when used under appropriate conditions and in accordance with appropriate instructions for a period of no less than one year from the date of shipment of the product.*

*Accurate Gas control Systems' sole obligation shall be to repair or replace at AGCS options FOB its plant or locally, without charge, any parts(s) that prove defective within the warranty period, provided the customer notifies AGCS promptly and in writing of any such defect. Compensations for labor by other than AGCS employees will not be AGCS obligation. Parts replacement does not constitute an extension of the original warranty period.*

*AGCS makes no warranty of merchantability, fitness for a particular purpose, or any other warranty, expressed or implied, as to the design, sale installation or use of its products, and shall not be liable for consequential damages resulting from the use of its products.*

*While AGCS personnel are available to advise customers concerning general applications of all manufactured products, oral representations are not warranties with respect to particular applications and should not be relied upon if inconsistent with product specifications of the terms stated herein.*

*In any event, the terms and conditions contained in the AGCS formal sales contracts shall be controlling; and any changes must be in writing and signed by an authorized executive of AGCS.*

*Defective switches, temperature indicators, heaters, temperature controlling devices, and compressors will be replaced without charge one year from the date of shipment. There will be no charge for labor if the unit is returned to the factory prepaid.*

*Conditions and qualifications of warranty statement shall prevail at all times.*

*AGCS will not assume responsibility for unauthorized repairs or failure as a result of unauthorized product modifications, or for repairs, replacement, of modifications negligently or otherwise improperly made or performed by persons other than AGCS employees or authorized representatives.*



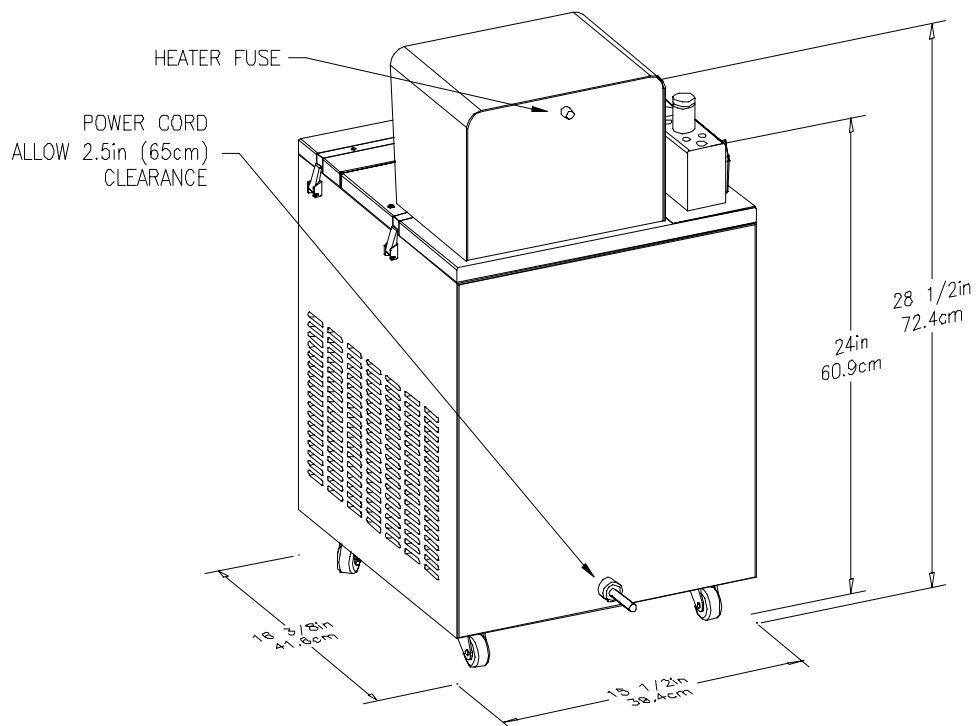
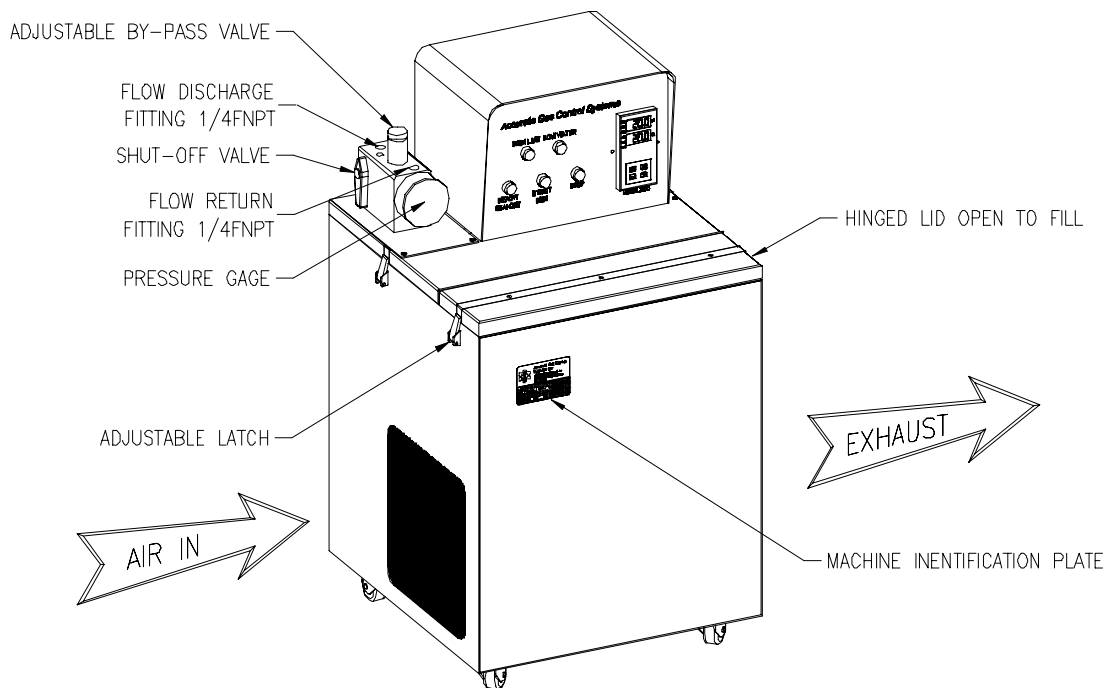

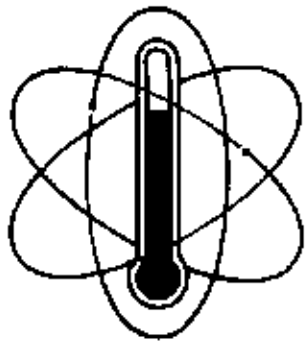

# ***ACCURATE***

*GAS CONTROL SYSTEMS, Inc.*

*AGT354C*  
*Chiller/Heater Recirculator*  
*Installation and Operation Manual*

*2825 South Rodeo Gulch Rd. • Soquel • California • 95073*  
*PH (831) 462-0500 • FX (831) 462-0507 • [accurategas.com](http://accurategas.com)*

Doc No 30006